

Blaze 850/1000w Pro

A Luxury Scooter Like No Other

40.39mi range / faster and more stable

Blaze 850w Pro Launch, Spring Festival Debut Domineering exposed, Glittering in Strong Realm, Boogie Style, Dominated the world.



Quick folding



The LED lamps



Lithium battery pack



The brake system

25°

Climbing Angel

40.39mi

Max Range

220lbs

Load range

50.71lbs

Net Weight







Toughness Magnesium Alloy One Die Casting Molding

Car painting process, as new bearing ten thousand times detection,
make the vehicle safer and more stylish to simple, to true.
Tough magnesium alloy integrated curved frame,
stable and durable light and portable



- ✓ Simplify design
Concise body without any exposed wire
- ✓ Originality with unique concept
Design of hidden battery in automobile chassis
- ✓ Fast folding
Distinctive design, automatic folding lock

Upgraded Version Folding Automatic Lock Design

The car-level folding structure safety lock, safe and stable, not easy to shake. You can complete the folding of the pole with just one click, one buckle and one press, which solves the problem of handling and storage of the vehicle after driving



Folding automatic lock



In the office



Put inside trunk



Put in the elevator



With High Efficient Concentrated Power Lithium Battery

Like "Tesla" in E-Scooter industry, power type lithium battery, high power supply safe and durable performance, kinetic energy into electric energy, and long endurance

Tip: batteries according to local climate, humidity, the road to decide life mileage

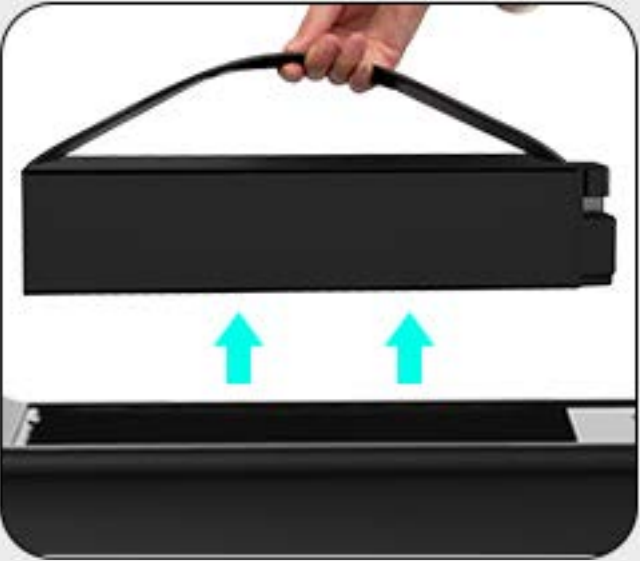

Lift up the battery strap vertically and take it out.

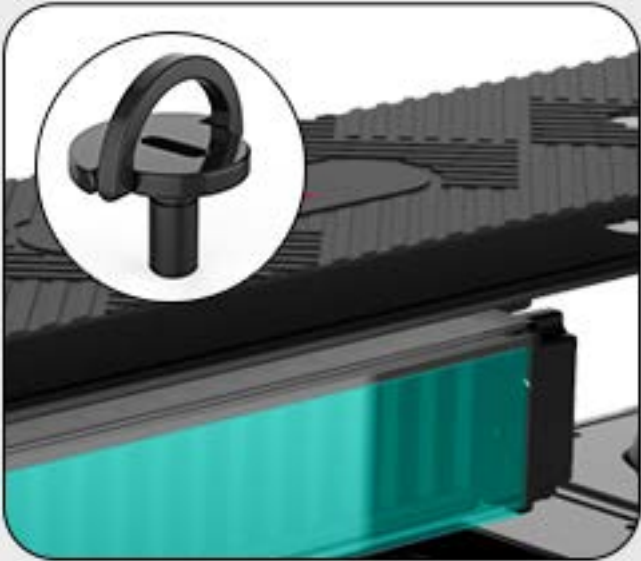

Gently turn the two quick-release screws, then remove the battery.

6 intelligence protection

-  Short circuit protection
-  Over current protection
-  Double over charge protection
-  Double over discharge protection
-  Temperature anomaly protection
-  Undervoltage automatic sleep



Front And Rear Vacuum Explosion-Proof Suspension Tires

The 10" front and rear vacuum explosion-proof tires are made of memory Jell-vacuum tires, which can pass through most urban roads and deceleration belts smoothly. It is wear-resistant and anti-skid, with large wheel diameter vacuum shock absorption, and the riding on brick road and gravel road will never be broken and will not leak, and it can also maintain a comfortable riding



Resistance rubber

Non-slip

Explosion-proof

Wear-resisting

*cement, uneven, flat, mud, bricks, gravel road cycling



Fully Showing Heroism Without Showing Up

Front & Rear disc brake, E-ABS anti-lock electric brake,
Rear foot brake Double hand-grip brake system
Effectively shorten braking distance Efficient braking,
quick response, Ensure safe riding

Double wrap
the brake



Rear foot brake

Front disc brake

Rear disc brake

HD LED Dashboard

Power, Speed At A Glance

Equipped with HD large screen, Display remaining power and speed timely, Better acknowledge of scooter status.

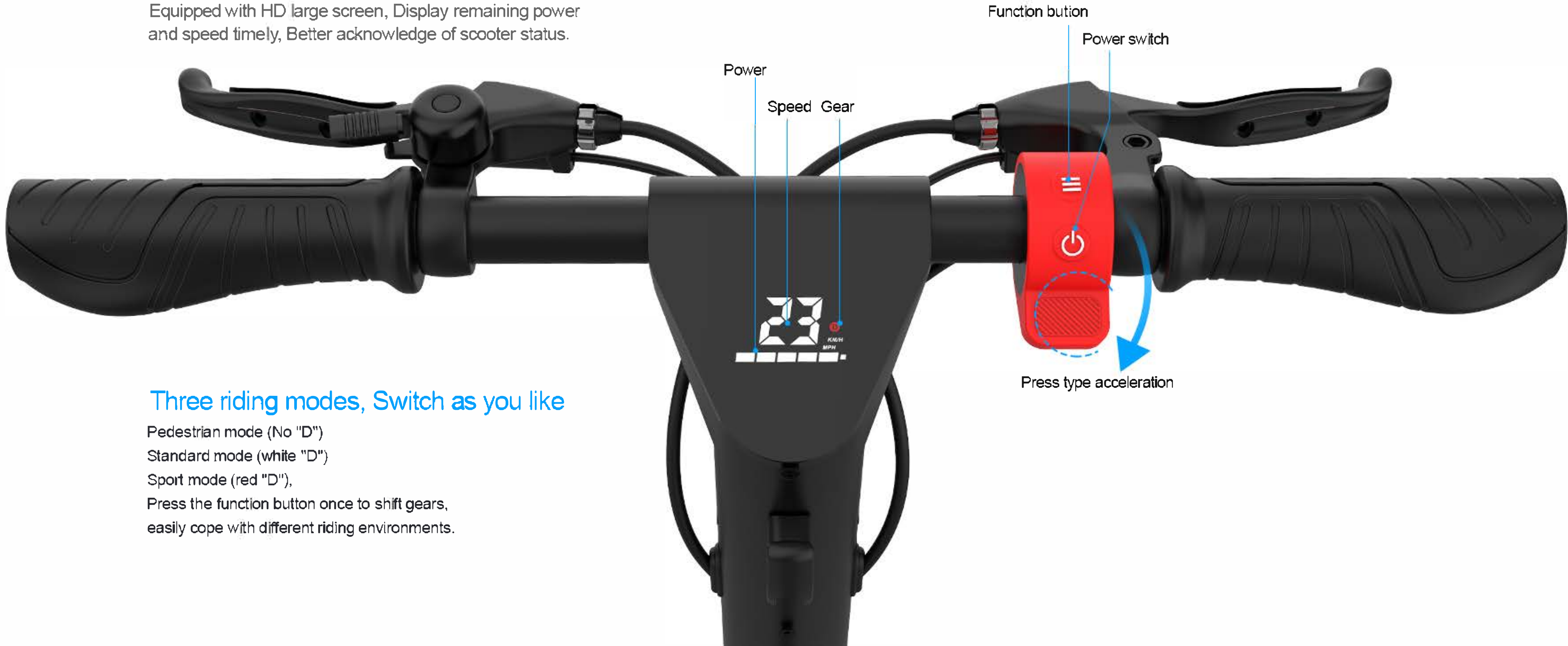

Three riding modes, Switch as you like

- Pedestrian mode (No "D")
 - Standard mode (white "D")
 - Sport mode (red "D"),
- Press the function button once to shift gears, easily cope with different riding environments.

Super Performance Output

1000W high-speed brushless motor strengthens the ability to overcome obstacles Powerful but not sharp, prominent but not abrupt
Back Tech support.Tech Geek Gospel

850w

Rated Power

28mph

Speed

1000w

Maximum
Output Power

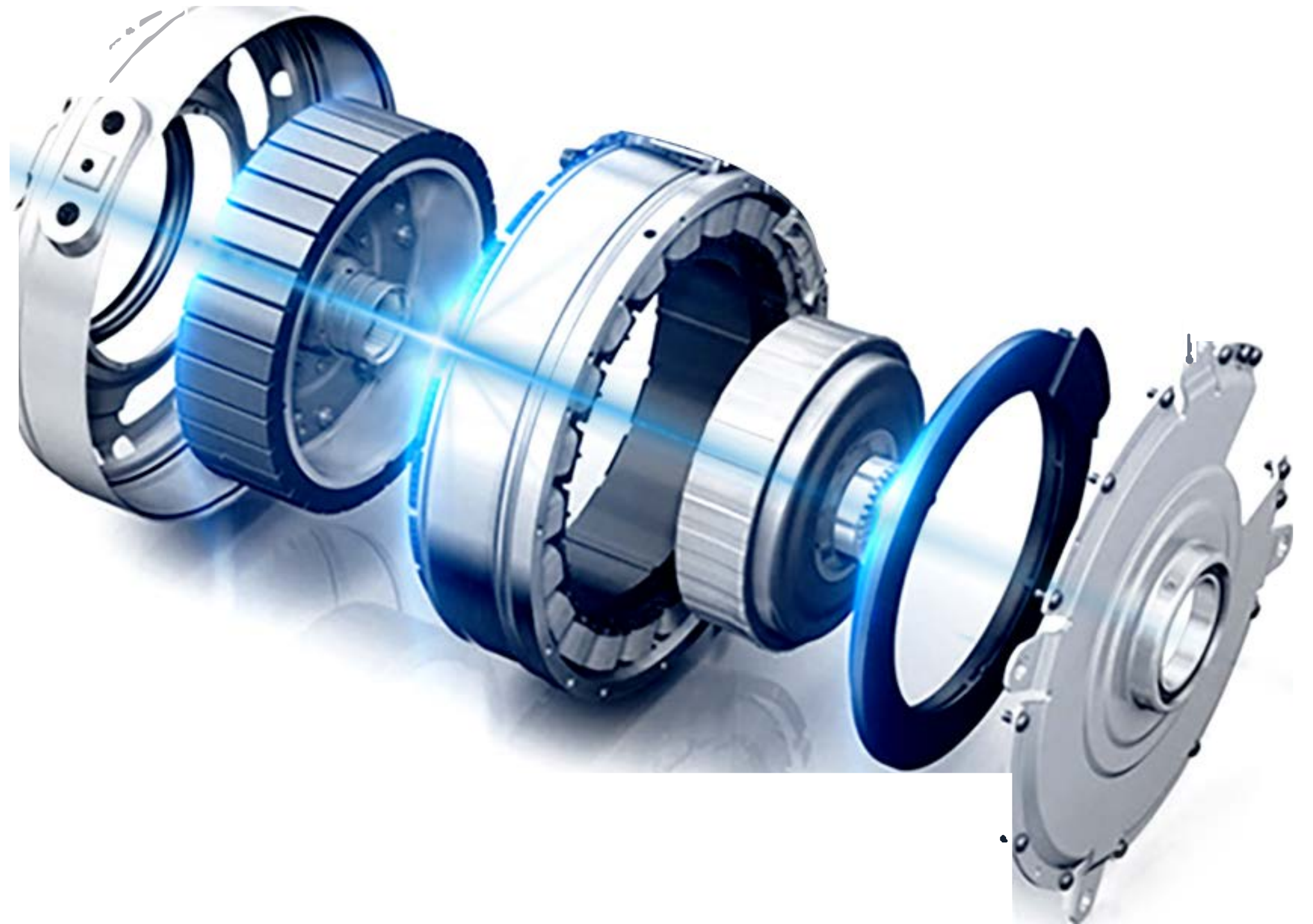

LED Headlamps

It lights up the nighttime road. Meantime, the rearwaming brake light reminds the pedestrians behind to keep a safe distance



25° Climbing Angle

Instantly, feeling the powerful motor when you press the accelerator SUV power in an electric scooter field, an electric scooter is capable to be faster on the steep road, hilly road, uneven road and sandy road



Details Of Appreciation

Easy cycling, it is a beautiful city landscape



Pedestrian indicator

Lights up when the speed is lower than 4mph
Turn off when speeds higher than 4mph

Non-slip grip texture

It adopts arc-shaped design with smooth and beautiful texture, comfortable and non-slip.



Creative bells

Buzzer & bell to remind pedestrians or vehicles ahead to drive safely



Pedal wide

Compatible with human body upright riding with feet together, much more comfortable.
Pedal Width: 7.2in

7.20in

Product Size

48.5in



Open Size
43.3*19.7*48.5in

43.3in

21.25in



Fold Size
43.7*19.7*21.25in

43.3in

Optional Color

Black



White



Orange

